

SAPPHIRE (SHDSS)

The SHDSS cable cleat range consists of metallic cable cleats which have been designed, constructed, and tested in accordance with the International Standard IEC 61914: Cable cleats for electrical installations.

The SHDSS cable cleat has been designed and tested for high short circuit conditions on cables held in single, parallel / flat formation, to ensure the securing and retention of cables without damage to the cable(s).

The Sapphire cable cleat is available for single parallel formation for diameters of 19 to 150mm in 13 sizes. The cable cleat is fabricated from 316L stainless steel, giving it high creep strength whilst providing excellent corrosion resistance in the harshest of environments.

The Sapphire cable cleat has one M12 and two M10 fixing clearance holes within its base, allowing versatility to the installer during installation, and is designed to enable the product to be secured to a variety of mounting surfaces. The Sapphire cable cleat hinge opens fully, allowing the cables to be easily placed within the cable cleat, to aid the installer before closing and securing via the mouth piece bolt.

The Sapphire cable cleats come with liners as standard, helping to restrain the cables within vertical applications, providing a layer of protection between the cable sheath and the cable cleat during normal operation, where thermal elongation of cable occurs, protecting the cable from chafing on any mounting surface due to differential movements such as those found in marine and offshore applications. The liners also assist in the extra protection of cables in the event of short circuit fault conditions. The standard liners supplied are classified as Low Smoke & Fume (LSF), Zero Halogen (LSOH) and Phosphorus Free.



FEATURES

- Third party certification to IEC 61914
- 316L stainless steel
- 19 to 150mm in 13 sizes for single / parallel formation
- Operating temperature -60°C to +60°C
- Standard Polymer Liners are classified as Low Smoke and Fume Zero Halogen (LSFOH), Phosphorus-free
- Combined single (M12) and two bolt (M10) fixing design

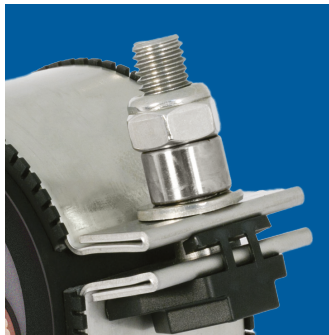

TECHNICAL DATA & CLASSIFICATION

TYPE	6.1.3 Composite SHDSS - Single Heavy Duty Stainless Steel
DESIGN SPECIFICATION	IEC 61914
TEMPERATURE FOR PERMANENT APPLICATION	-60°C to +60°C IEC 61914 clause 6.2
NEEDLE FLAME TEST	Pass - 120 second flame application time IEC 61914 clause 10.0, 10.1, IEC 60695-11-5
LATERAL LOAD TEST	3.5kN - 14.5kN, IEC 61914 clause 9.3
AXIAL LOAD TEST	0.2kN - 0.9kN, IEC 61914 clause 9.4
IMPACT RESISTANCE	Pass - Very heavy IEC 61914 clause 6.3, 6.3.5, 9.2
MATERIAL	316L Stainless Steel with Standard Polymer Liner Standard Polymer Liners are classified as Low Smoke & Fume (LSF), Zero Halogen (LSOH) and Phosphorus Free

SHORT CIRCUIT TESTING TO IEC 61914 - CLAUSE 9.5

MULTICORE FORMATION		PARALLEL FORMATION	
One short circuit 600mm fixed cleat centres	Two short circuits 600mm fixed cleat centres	One short circuit 600mm fixed cleat centres 105mm cable centres	Two short circuits 600mm fixed cleat centres 105mm cable centres
0.1 sec	0.1 sec	0.1 sec	0.1 sec
105kA Peak	105kA Peak	110kA Peak	109kA Peak
50.0kA r.m.s	50.0kA r.m.s	50.0kA r.m.s	50.0kA r.m.s

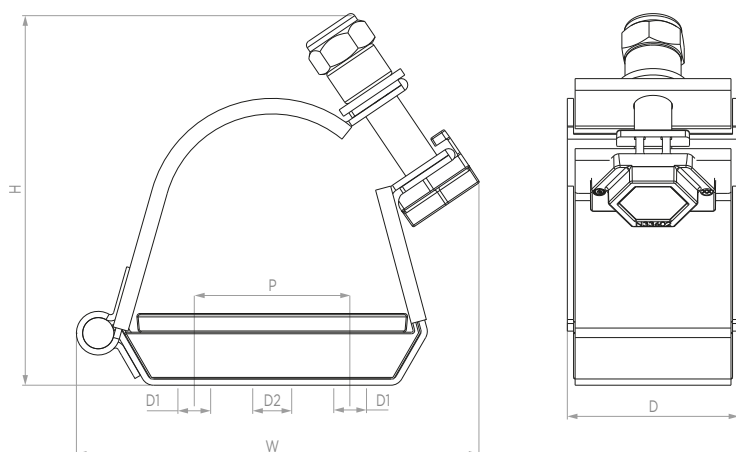
**CABLE CLEAT SELECTION TABLE**

PART NO.	CABLE Ø RANGE TAKE (MM)	DIMENSIONS MM				FIXING HOLE Ø		WEIGHT (g)
		W	H	D	P	D1	D2	
SHDSS019026	19-26	94	85	54	25	2 x M10	1 x M12	395
SHDSS026032	26-32	95	88	54	25	2 x M10	1 x M12	402
SHDSS032038	32-38	96	93	54	25	2 x M10	1 x M12	431
SHDSS038046	38-46	100	100	54	25	2 x M10	1 x M12	446
SHDSS046051	46-51	104	103	54	25	2 x M10	1 x M12	456
SHDSS051058	51-58	108	107	54	25	2 x M10	1 x M12	472
SHDSS058070	58-70	129	119	54	50	2 x M10	1 x M12	554
SHDSS070083	70-83	137	120	54	50	2 x M10	1 x M12	581
SHDSS083097	83-97	157	137	54	75	2 x M10	1 x M12	665
SHDSS096109	96-109	165	133	54	75	2 x M10	1 x M12	688
SHDSS106120	106-120	170	142	54	75	2 x M10	1 x M12	713
SHDSS120135	120-135	197	157	54	75	2 x M10	1 x M12	814
SHDSS135150	135-150	205	172	54	75	2 x M10	1 x M12	847